

[Reset](#)
[Download 3D Model](#)

Code Number	CCM	* L 1 mm./inch.	* L 2 mm./inch.	* L 3max mm./inch.
151F0500	80	124.1[4.89]	146.1[5.75]	max. 168.4[6.63]
151F0501	100	127.5[5.02]	149.5[5.89]	max. 171.8[6.76]
151F0502	125	131.9[5.20]	153.9[6.06]	max. 176.2[6.93]
151F0503	160	137.9[5.43]	159.9[6.30]	max. 182.2[7.17]
151F0504	200	144.9[5.70]	166.9[6.57]	max. 189.2[7.45]
151F0505	250	153.6[6.05]	175.6[6.91]	max. 197.9[7.80]
151F0506	315	164.9[6.49]	186.9[7.36]	max. 209.2[8.24]
151F0605	400	178.5[7.03]	200.5[7.89]	max. 222.8[8.77]
151F0655	500	178.5[7.03]	200.5[7.89]	max. 222.8[8.77]

C: Drain connection
G 1/4; 12[0.47] deep
D: M10; 13[0.51] deep
E: G 1/2; 16[0.63] deep

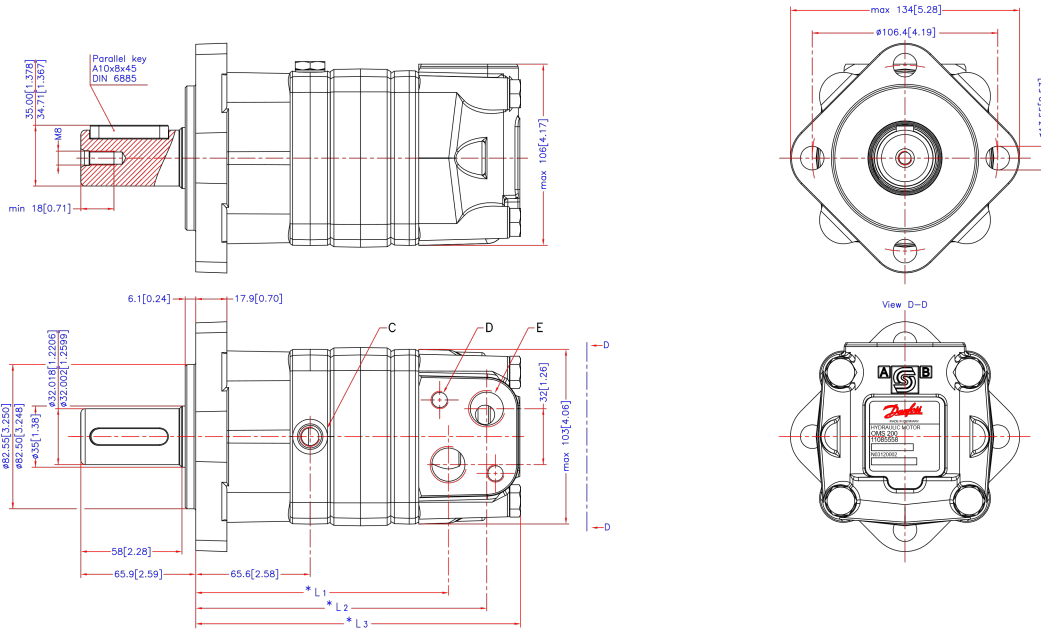

Tolerance for basic dimensions = ±1 mm (0.04 inch)

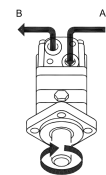
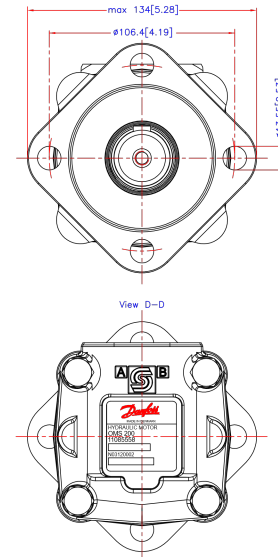

Altered	Reason	Date	Scale	Projection	Confidential	OMS
-	-	-	1:1	1st Angle	Property of Danfoss (Herborg) A/S, Denmark. Not to be handed over to, copied or used by third party. Use of three-dimensional reproductions of contents to be authorized by Danfoss (Herborg) A/S. Danfoss (Herborg) A/S can accept no responsibility for possible errors on drawings. Danfoss (Herborg) A/S reserves the right to alter product design or other information without notice. All alterations can be made without subsequent changes being necessary if specifications already agreed.	ø32 cyl.
			Date: 2013.10.31	Designer: ASJ	Approb.	NO. 8_151D0560